

**AUTOMATIC BAR SCREEN
WITH DOWNSTREAM WASTE DISCHARGE
FOR FLOWS UP TO 25 000 m³/h**

SPECIFICITIES

- Downstream waste discharge
- Installation only into channels
- Simple design = long-term reliability
- Custom built
- Low operating costs and easy maintenance
- Parts subject to wear and electrical equipment are out of water
- Waste directly discharged into a trash container or other container

TECHNICAL CHARACTERISTICS

Max. Flow	25 000 m ³ /h
Bar Spacing	10 to 100 mm
Width	800 to 3 000 mm
Max. Depth under Installation Plane	12 000 mm
Max. Total Height	18 000 mm
Discharge Side	Downstream
Slope	15°
Material	304L, 316L or mixed
Electrical Protection	Current Controller



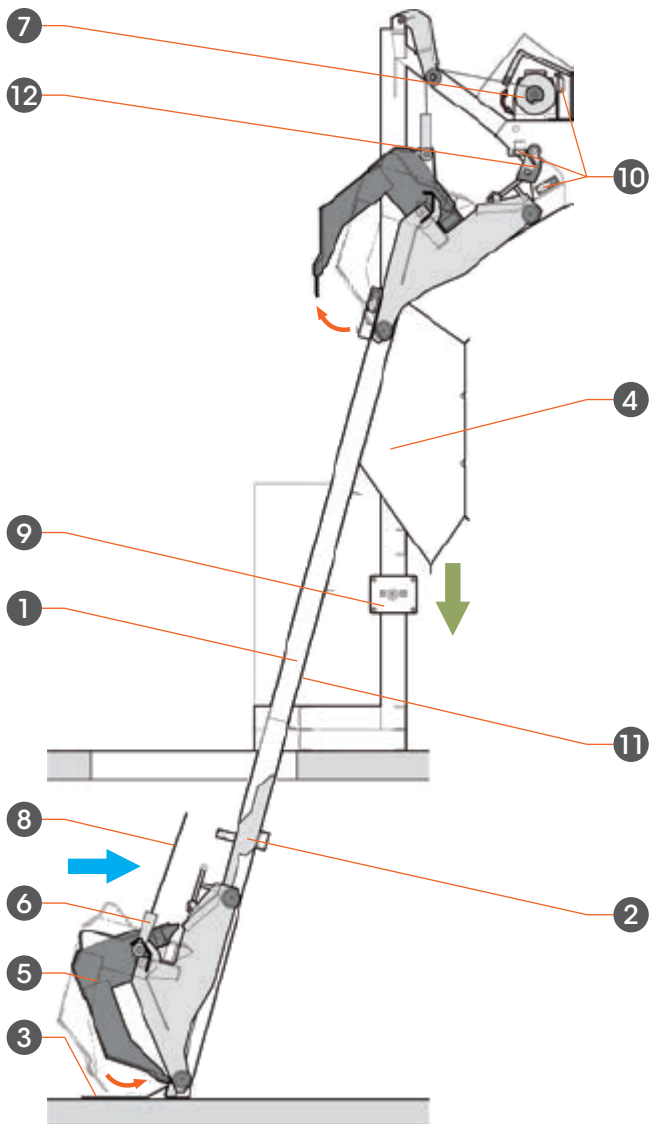

1 • FRAME

With attachment parts (by fastening or embedding).

2 • FIXED SCREEN

Bar spacing on request.

3 • COLLECTION RECEPTACLE

4 • WASTE DISCHARGE HOPPER

5 • SCOOP/CARRIAGE ASSEMBLY

The carriage slides in the rails. The scoop is equipped with a comb to clean the screen.

6 • MOBILE PART

Attached to the end of the strap, it initiates the opening or closing of the scoop according to its position.

7 • GEARED MOTOR

(SEW, P=0,37 to 2,2kW), with single-strap drum. Protected by hinged casing equipped with a pneumatic actuator.

8 • POLYESTER STRAP

Resistant to all chemical products and freezing.

Breaking strength = 5 or 12 tons according to bar screen dimensions.

9 • MANUAL CONTROL PANEL

Equipped with «up-down» pushbuttons and an emergency stop punch button. The geared motor and limit sensors are connected to it.

10 • POSITION SWITCHES

«Top», «Very Top» and «Bottom».

11 • WASTE GUIDE

12 • LOCK

OPERATING PRINCIPLE

On receiving the operation signal, the open scoop/carriage assembly slides down to come to rest on the collection receptacle. Under the effect of gravity, the mobile part changes position, the strap slackens and releases a feeler which actuates the « bottom » limit sensor. The motor operating direction is then reversed, the strap is tightened, the scoop closes engaging its teeth in the screen and is raised. At the top, the scoop/carriage assembly follows the rails angle. At the level of the hopper inclined plane, waste falls down. The «top» end of travel sensor stops the motor and actuates the reverser. The scoop/carriage assembly slides back down and comes to a stop on the lock. The strap slackens and releases the feeler which actuates the «bottom» end of travel sensor. The motor operating direction is reversed again, the strap is tightened, the mobile part changes position and opens the scoop. The «very top» limit sensor stops the motor and actuates the reverser the open scoop/carriage assembly slides down again for a new cycle.

OPTIONS

Frame made up of several parts according to the depth or location (in building for example), lateral deflectors, ATEX Equipment, variable speed geared motor, electrical control and servo-control unit with or without variable speed drive, etc.